

Harman Kardon AVR11 Audio/Video Receiver

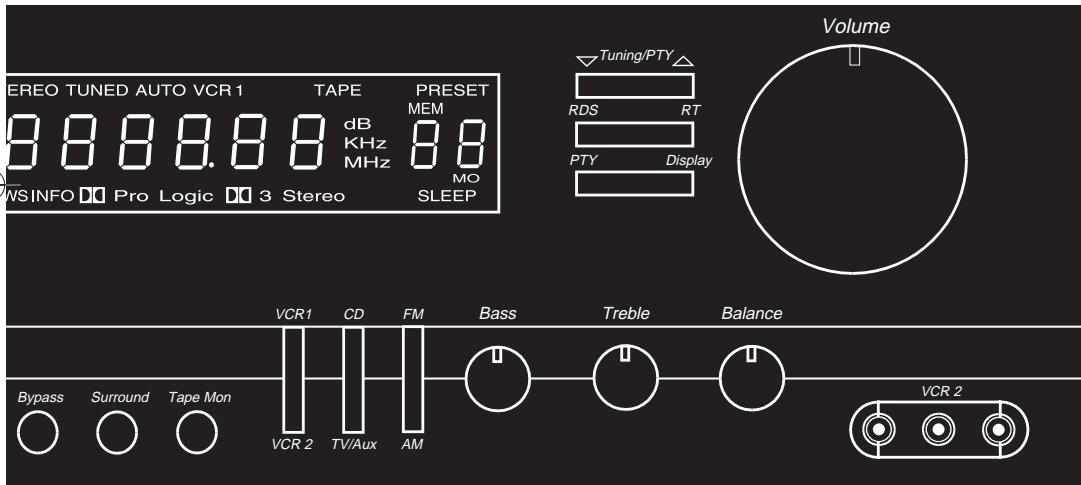

Owner's Manual

harman/kardon

Declaration of Conformity



We, Harman Kardon Europe A/S
Kongevejen 194B
DK-3460 Birkerød
DENMARK

declare in own responsibility, that
the product described in this
owner's manual is in compliance
with technical standards:

EN 55 013/6.1990
EN 55 020/6.1988
EN 60 065/1994
EN 60 555-2-3/1987/88

A handwritten signature in black ink, appearing to read 'Steen Michaelsen'.

Steen Michaelsen
Harman Kardon Europe A/S
Birkerød, DANMARK, 7/96

Front Panel

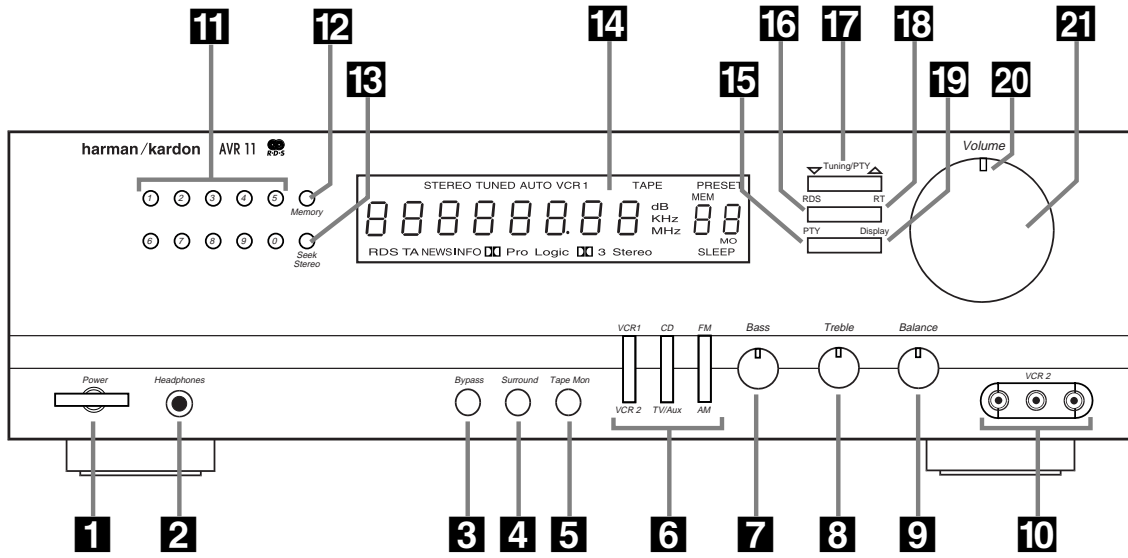

- 1** Power Button
- 2** Headphones Jack
- 3** Bypass Button
- 4** Surround Mode Select Button
- 5** Tape Monitor Button
- 6** Input Selector Buttons
- 7** Bass Control

- 8** Treble Control
- 9** Balance Control
- 10** VCR 2 A/V Input Jacks
- 11** Station Preset Buttons
- 12** Memory Button
- 13** Seek/Stereo Button
- 14** Information Display Window

- 15** PTY Search Button
- 16** RDS Control Button
- 17** Tuning/PTY Select Button
- 18** RT (Radio Text) Selector
- 19** RDS Display Button
- 20** Power/Mute Indicator
- 21** Volume Control



Rear Panel

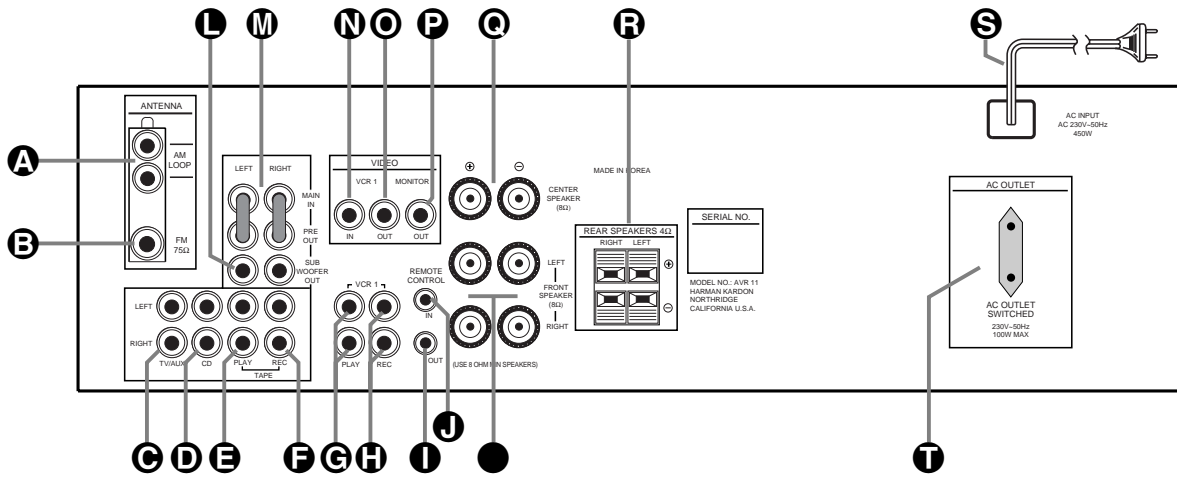

- A** AM Antenna Input
- B** FM Antenna Input
- C** TV/AUX Input Jacks
- D** CD Input jacks
- E** Tape Input (Play) Jacks
- F** Tape Output (Rec) Jacks
- G** VCR1 Audio Input (Play) Jacks
- H** VCR1 Audio Output (Rec) Jacks
- I** Remote Control Out Jack
- J** Remote Control In Jack
- K** Front Left/Right Speaker Terminals
- L** Subwoofer Output Jacks
- M** Left/Right Pre Out/Main In Jacks
- N** VCR1 Video Input (Play) Jack
- O** VCR1 Video Output (Rec) Jack
- P** Video Monitor Jack
- Q** Center Channel Speaker Terminals
- R** Rear Speaker Terminals
- S** AC Mains Power Cord
- T** Switched AC Outlet

Driving the Front Speakers with another Amplifier

(Remove PRE-OUT/MAIN IN jumpers when the front speakers are connected to an external amplifier)

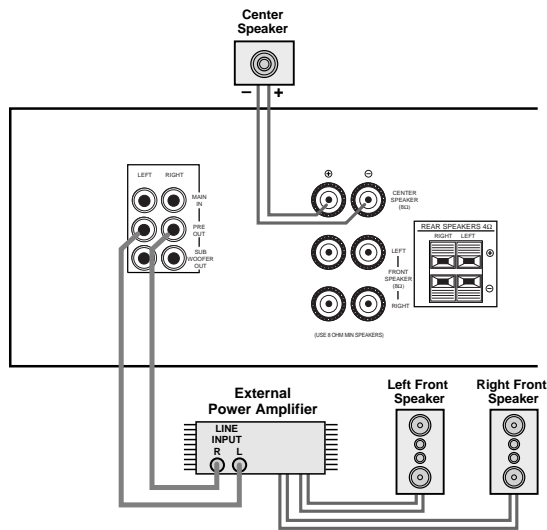

Driving an External Subwoofer Amplifier

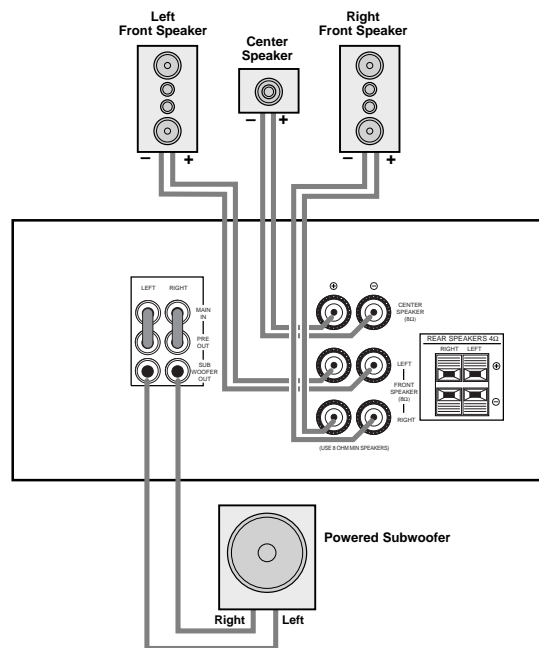

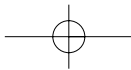

Remote Control

- 1 IR Transmitter Window
- 2 Standby Button
- 3 Tuning Up/Down
- 4 Preset Scan
- 5 Numeric Buttons
- 6 CD Function Buttons
- 7 Cassette Deck Function Buttons
- 8 Delay Time Button
- 9 Input Function Selector
- 10 Center Level Up/Down Buttons
- 11 Center Mode Button
- 12 Test Tone Button
- 13 Rear Level Up/Down Buttons
- 14 Master Volume Buttons
- 15 Display Button
- 16 Sleep Button
- 17 Mute Button

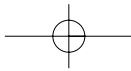
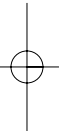
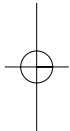
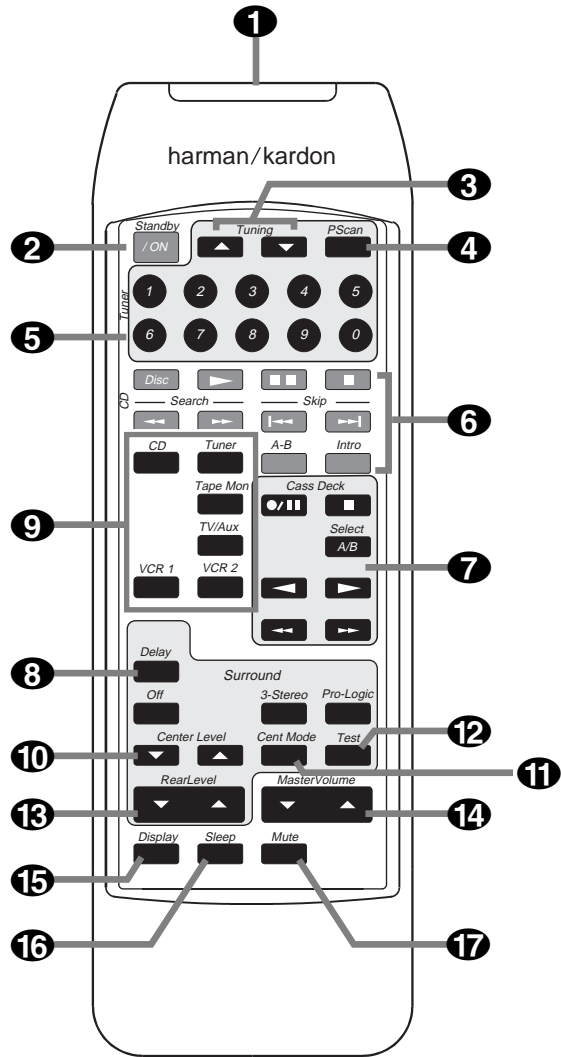

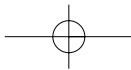
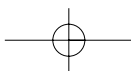
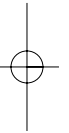
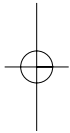
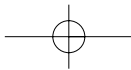

Table of Contents

Introduction and Safety Information	1
Front Panel Controls	2-3
Rear Panel Connections	4
System Remote Control	5-6
Installation & Configuration	7-9
Operation	10-13
Troubleshooting Chart	14
Technical Specifications	15





Introduction and Safety Information

ENGLISH

Thank you for choosing a Harman Kardon Audio/Video Receiver.

Your new unit is an exceptionally well-engineered product that will give you years of superb performance.

Save all packing material.

It is essential for shipping should you move, or in the event the unit ever needs repair.

Handle the Power Cord Gently

- To disconnect the plug from the AC outlet, pull on the plug itself, not on the cord.
- Disconnect the plug from the AC outlet whenever the unit is to be left unused for an extended period of time.
- Do not place furniture or other heavy objects on the cord, and avoid dropping heavy objects on it. Also do not make a knot in the cord.

Place the unit on a firm and level surface

Avoid installing it:

- In moist or humid places
- Close to heating equipment or in places exposed to direct sunlight
- In a direct draft from an air conditioner or in other very cold locations
- In places subject to excessive vibration or dust
- In poorly ventilated places

Moving the Unit

Before moving the unit, be sure to unplug the power cord from the AC outlet and disconnect all wires to antennas and other components.

Do Not Open the Cabinet

Do not attempt to service this unit. Tampering with internal components can cause fire or shock, and may void your guarantee. If water or a small object enters the unit, unplug the power cord immediately and consult an authorized Harman Kardon service center. Using the unit under such conditions may cause a fire or shock hazard.

Cleaning

Remove dust by wiping the unit with a soft, dry cloth. If necessary, use a soft cloth lightly dampened with mild soapy water; then wipe with a dry cloth. Never use benzene, thinner, alcohol or other volatile agents, and avoid spraying insecticides near the unit.

CAUTION: Any changes or modifications in construction of this device which are not expressly approved by the party responsible for compliance could void the user's authority to operate the equipment.

Conventions

In order to help you use this manual with the remote control, front panel controls and rear panel connections, certain conventions have been used.

EXAMPLE – (bold type) indicates a specific remote control or front panel button, or rear panel connection jack

EXAMPLE – (OCR type) indicates a message that is visible in the display window

1 – (number in a square) indicates a specific front panel control

1 – (number in an oval) indicates a button on the remote

A – (letter in a circle) indicates a rear panel connection

	CAUTION RISK OF ELECTRIC SHOCK DO NOT OPEN	
<p>CAUTION: TO REDUCE THE RISK OF ELECTRIC SHOCK, DO NOT REMOVE COVER (OR BACK). NO USER-SERVICEABLE PARTS INSIDE. REFER SERVICING TO QUALIFIED SERVICE PERSONNEL.</p>		
	<small>The lightning flash with arrowhead symbol, within an equilateral triangle, is intended to alert the user to the presence of uninsulated "dangerous voltage" within the product's enclosure that may be of sufficient magnitude to constitute a risk of electric shock to persons.</small>	
<p>WARNING: TO REDUCE THE RISK OF FIRE OR ELECTRIC SHOCK, DO NOT EXPOSE THIS APPLIANCE TO RAIN OR MOISTURE.</p>		
<p><small>The exclamation point within an equilateral triangle is intended to alert the user to the presence of important operating and maintenance (servicing) instructions in the literature accompanying the appliance.</small></p>		

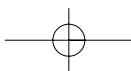

Front Panel Controls

2

1 POWER Button: Press this button to turn the power totally on and off (not remutable, see also page 10).

2 HEADPHONES Jack: Stereo headphones may be plugged into this jack for private listening. Headphone impedance should be between 8 ohms and 2K ohms. Best results are between 200 and 400 ohms.

3 BYPASS Selector: Defeats all surround modes.

4 SURROUND MODE Selector: Press this button to select the desired surround mode. The mode is changed between normal DOLBY Pro-Logic and DOLBY 3-STEREO.

5 TAPE MONITOR Button: Press this button to select input from a tape deck or to monitor a recording in progress (with 3 head decks).

6 INPUT Selector Buttons: Press these buttons to select the desired input source.

7 BASS Control: Modifies the low-frequency sound of the left and right channels as much as ± 10 dB. Set this control at a suitable position for your taste and room acoustics.

8 TREBLE Control: Modifies the high-frequency sound of the left and right channels as much as ± 10 dB. Set this control at a suitable position for your taste and room acoustics.

9 BALANCE Control: This control is used for balancing the relative sound volume of the left and right channel speakers. Clockwise rotation reduces the volume from the left speaker, counterclockwise rotation reduces the volume from the right speaker.

10 VCR2 A/V INPUT Jacks: Connect these jacks to the corresponding output jacks of a VCR (Yellow: Video, Red/White: Audio).

11 STATION PRESET Buttons: These buttons are used to recall or store preset stations. Pressing the buttons will automatically choose the tuner as an input and switch to the selected station. Pressing the buttons after pushing **MEMORY 12** will store a station's frequency to the desired location.

NOTE: To select or enter a preset location between 10 and 29 you must select the second digit within 2 seconds of the first. To select preset location 30, simply press **0**.

12 MEMORY Button: Press this button to store an AM or FM frequency in the unit's memory. The **MEMORY** indicator will blink in the display to remind you to choose a location using the **STATION PRESET 11** buttons. Storing a station in a memory location that has already been used will overwrite the existing data.

NOTE: The preset memories are protected from power loss for two weeks. If the unit is totally switched off or unplugged for more than two weeks, all stored frequencies will be erased.

13 SEEK / STEREO Button: Press this button, **AUTO** will illuminate in the display and the tuner automatically switches to Mono or Stereo mode correspondingly to the received signal. Then press the Tuning/PTY **▼** or **▲** button. The tuner will automatically seek out stations in your area that have enough signal strength to be listenable.

14 DISPLAY WINDOW: The indicators in this display provide information about the input source, tuner/ RDS operation and surround options. The IR remote sensor is also behind this window.

NOTE: For optimal operation of the remote control be certain that the window is not blocked by cabinet doors or other obstructions.

15 PTY (Program Type Search): When the RDS system is engaged by pressing **RDS 16**, this button is used to initiate a search for stations with a specific Programme Type (PTY). Press this button and note that **PTY SEL** appears in the display window. Use the **TUNING/PTY 17** to scroll through the list of available PTY types and press the PTY-button again to scan for your selection. The display will indicate the preset number for all stations with the correct PTY and tune to the strongest.

Front Panel Controls

3

ENGLISH

16 RDS Selector: Press this button to activate the RDS-search-system. Note that **RDS** will appear in the display window. Pressing the **TUNING/PTY 17** buttons will advance the tuner to the next available station that is transmitting RDS data. Press the RDS-button again to resume tuning of all stations. See page 11 for complete information on the RDS system.

17 TUNING/PTY ▲ ▼: When the tuner is selected, pressing ▼ tunes to stations with lower frequency, pressing ▲ tunes to higher frequencies. This button is also used to scroll up or down through the list of PTY choices when the RDS system is in use.

18 RT Selector: When the RDS system is engaged by pressing **RDS 16**, pressing this button will display a scrolling text message with additional data about the station or programme being transmitted. If there is no RT message the display will indicate **NO TEXT**.

19 RDS DISPLAY Button: Pressing this button when the RDS system is engaged will change messages in the display window. The normal display is the Station Name. Press the button once to display the Programme Type (PTY) and again to show the correct clock time (CT). Press again to show the station's frequency and again to return to the Station Name. If no data is available for the station being tuned, a message to that effect will appear in the display.

20 POWER/MUTE: This indicator will glow in a green color whenever the unit is turned on and its position gives you a relative indication of the volume level. When the volume is muted by pressing the **MUTE 17** button on the remote, the indicator will flash as a reminder that the unit is on, but the speaker output has been temporarily silenced.

21 VOLUME Control: Turn the knob clockwise to increase the volume and counterclockwise to decrease it. The volume of the front, center and rear channels is changed at the same time. Note that the volume control is motorized, and will rotate automatically when the volume is changed with the remote control.

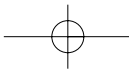

Rear Panel Connections

4

A AM ANTENNA INPUT: Assemble the AM Loop antenna as shown, and connect it to these terminals. Tune in your favorite AM station and position the loop antenna for best reception. Try other stations and find the position that gives the best overall reception. When this unit is mounted in a rack or placed on a shelf with sufficient space behind, hang the antenna on a wall in the direction which gives the best reception.

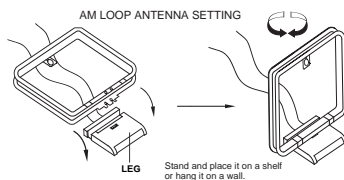

NOTE: If noise is heard during AM reception, move the antenna for better reception.

B FM ANTENNA INPUT: Connect the supplied antenna (the wire lead) to this jack. You may need to change the position of the antenna for best reception of your favorite stations and for optimal decoding of RDS information. In some locations an outdoor antenna may be required. Connect it to these terminals using a 300Ω/75Ω adapter if your antenna system uses no 75 ohms coaxial cable.

C TV / AUX AUDIO INPUT Jacks: This input is provided for any audio source. An additional compact disc player, tape recorder, TV-tuner, video cassette recorder (VCR), etc. may be plugged into these jacks (only for Audio playback).

D CD INPUT Jacks: Connect the output cables of a compact disc player to these jacks.

E TAPE INPUT (Play) Jacks:

Connect the line output of your CASSETTE DECK to these jacks.

F TAPE OUTPUT (Rec) Jacks:

Connect the line input of your CASSETTE DECK to these jacks.

G VCR1 AUDIO INPUT (Play) Jacks:

Connect these jacks to the audio Output/Play jacks on your VCR

H VCR 1 AUDIO OUTPUT (Rec) Jacks:

Connect these jacks to the audio Input/Record jacks on your VCR.

I REMOTE CONTROL OUT Jacks:

Connecting this jack to another compatible Harman Kardon product with a mono 3.5mm cord set will enable the IR sensor in the AVR11 to pass remote commands through to additional devices.

J REMOTE CONTROL IN Jack:

When the infrared sensor behind the information window is blocked, or you are using a multiroom control system, the Remote Control output of an unblocked remotable unit or an external IR sensor such as the Harman Kardon HE1000 may be connected to this jack.

K FRONT SPEAKER Terminals:

Connect the front left (L) and right (R) speakers to these terminals. Make sure that the positive (+) and negative (-) terminals on the speaker are connected to the corresponding terminals on the receiver.

L SUBWOOFER OUTPUT Jacks:

When an external powered subwoofer is in use, connect these jacks to the line level input of the subwoofer's amplifier. Note that *BOTH* the left and right connections must be made. If a subwoofer is *NOT* in use, this jack may be used as an additional full-bandwidth Volume controlled Audio output.

M FRONT PRE OUT/MAIN IN Jacks

PRE OUT

When a separate power amplifier is used to drive the front speakers, connect the power amplifier input to these jacks.

MAIN IN

When a separate pre-amplifier is connected and this unit is used as a power amplifier, connect the pre-amplifier output to these jacks.

NOTE: Always connect the PRE OUT and MAIN IN jacks with the jumper plugs when you *DO NOT* use the PRE OUT and MAIN IN separately.

N VCR1 VIDEO INPUT (Play) Jack:

Connect this jack to the video output (play) of your VCR.

O VCR1 VIDEO OUTPUT (Rec) Jack:

Connect this jack to the video input (rec) of your VCR

P VIDEO MONITOR Jack: Connect this jack to a Video Input on your TV set or video projector. Select that input on the TV to view either of the VCRs selected by the AVR11.

Q CENTER SPEAKER Terminals:

Connect your center channel speaker to these terminals. Make sure that the positive (+) and negative (-) terminals on the speaker are connected to the corresponding terminals on the receiver.

R REAR SPEAKER Terminals:

Connect the left and right rear surround speakers to these terminals.

IMPORTANT NOTE: Both speakers must be connected for proper operation. If only one rear speaker is connected, no sound will be heard in the rear channel.

S AC MAINS POWER CORD: Plug this cord into wall mounted AC outlet.

T SWITCHED AC OUTLET: This outlet provides AC power when the unit is switched on totally (not Standby).

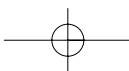

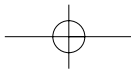

System Remote Control

1 INFRARED TRANSMITTER WINDOW: The infrared beam is emitted forward from this window when you press any button on the commander. For the remote control to function properly, always point this window toward the remote sensor window on the receiver and do not obstruct this window with any material.

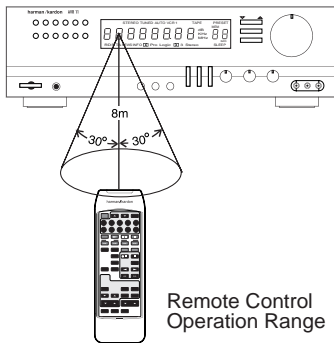

2 STANDBY Button: Press this button to turn the power on and off (from and to Standby mode). In order for this button to function, the front panel **POWER 1** button must be set to ON.

If you connect other components to the switched AC outlet, this Standby button can also be used as a system power button.

NOTE: Automatic power on: When you press the input function buttons (CD, TUNER, TAPE, TV/AUX, VCR 1, VCR 2) in STANDBY mode, the power is automatically turned on and the input is selected.

3 TUNING UP/DOWN: Press these buttons to tune the tuner frequency up or down.

4 PRESET SCAN Button: Press this button to scan preset stations (see page 11).

5 NUMERIC Buttons: These buttons can be used for preset tuning in **TUNER** mode.

Preset tuning: Select one of the 30 preset locations by pressing the numeric buttons directly, thereby the input of the receiver automatically is changed to **TUNER**.

6 CD FUNCTION Buttons: Use these buttons to control the transport and disc selection functions of a compatible Harman Kardon CD player or CD changer.

7 CASSETTE DECK FUNCTION Buttons: Use these buttons to control the functions of a compatible Harman Kardon cassette deck.

8 DELAY TIME Button: This button operates only in Dolby Pro Logic mode. In this mode the output signal from the surround speakers is delayed slightly from that of the front speakers.

Select appropriate delay time to achieve the best surround sound effect. For Dolby Surround sound, we recommend a 20ms delay. The time is changed as below, when the button is pressed in succession.

DOLBY PRO LOGIC MODE

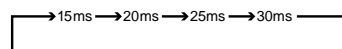

9 INPUT FUNCTION Selector: Press the button to select the desired input function. The available buttons are CD, TUNER, TAPE, TV/AUX, VCR 1, and VCR 2.

10 CENTER LEVEL UP/DOWN Buttons: Use these buttons to adjust the sound level of the center speaker to that of the front speakers. These buttons work only in Dolby Pro Logic and Dolby 3 Stereo mode. These buttons do not work in PHANTOM mode.

11 CENTER MODE Button: This button selects the center channel options for surround modes.

12 TEST TONE Button: Press this button to turn on the test signal generator for system setup.

13 REAR LEVEL UP/DOWN Buttons: These buttons operate only in Dolby PRO LOGIC mode. Use these buttons to adjust the sound level of the surround speakers. Set the MASTER VOLUME control at the desired level and then press these buttons until you get the optimum surround effect at your listening position.

14 MASTER VOLUME Buttons: Adjust the overall (Front, Center and Rear) volume level using these buttons.

15 DISPLAY Button Press this button to dim the display. Press it again to turn the display totally off and once more to return it to normal.

16 SLEEP Button This button sets the receiver to automatically turn off after 10, 20, 30, 60 or 90 minutes. Each time the button is pressed, the setting is advanced as below.

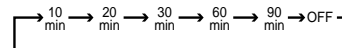

The display will dim when the sleep function has been set.

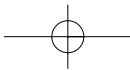

System Remote Control

6

17 MUTE Button

Press this button to silence the speakers temporarily. The **VOLUME 20** indicator will blink. Press again to restore the previous listening level.

18 BATTERY COMPARTMENT

To remove the cover, press it down with your thumb and pull it toward the back side. Two UM-3, size "AA" or R6 1.5V dry batteries are used. When loading the batteries, make sure that the polarity is correct. Remove the batteries from the case if the remote control will not be used for a long time.

NOTE: Please don't simply throw empty batteries away but recycle them as requested or return to your dealer.

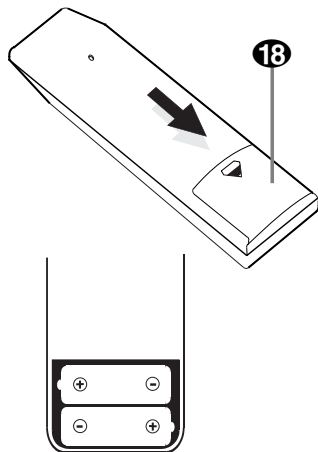

Slide the cover on the battery compartment as shown to remove. Insert the batteries being certain to observe proper polarity.

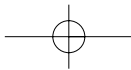

Installation & Configuration

Your new Harman Kardon receiver is designed to provide the best reproduction from both movies and musical programs. To assure that the unit operates to its fullest capability, it is important that you spend a few minutes to properly install and configure all the elements in your new system.

Speaker Selection and Placement

The placement of speakers in a multi channel home theater system can have a noticeable impact on the quality of sound reproduced. The AVR11 will deliver accurate reproduction with any high quality speakers.

No matter which type or brand of speakers are used, the same model or brand of speaker should be used for the front left, center and right speakers. This creates a seamless front soundstage, and eliminates the possibility of distracting sonic disturbances that occur when a sound moves across mis-matched front channel speakers.

For the most accurate and exciting reproduction of bass frequencies a separate subwoofer should be used.

Speaker Placement

For best imaging, it is recommended that the center channel speaker be placed in line with the left and right speakers. It should be placed above the center of TV monitor or rear screen projector, with the speaker as close to the top of the screen as possible. If possible, adjust the center channel speaker so that it is pointing towards the listening position. Once the center speaker is positioned, adjust the height of the left and right speakers so the tweeter of those speakers is no more than 60 cm off center from the tweeter on the center channel speaker.

Surround speakers should be placed on the side walls of the room with the center portion of the speaker facing directly toward the listening area. The speakers should be located at a position along the side wall that is between one-half and two-thirds the distance from the viewing screen or the front of the room to the rear of the room. The speakers should be located so that the bottom of the cabinet is at least 60 cm higher than the listeners' ears when in the desired area.

If side wall mounting is not practical, the speakers may be placed on a rear wall, behind the listening position. Again, they should be located so that the bottom of the cabinet is at least 60 cm higher than the listeners' ears. The speakers should be no more than 2 meters behind the rear of the seating area.

Subwoofers produce non-directional sound, so they may be placed almost anywhere in a room. Subwoofer placement is highly influenced by room size and shape, and the type of subwoofer used. Follow the instructions of the subwoofer's manufacturer, or experiment with the best location for a subwoofer in your listening room.

Speaker Connections

Once the speakers are positioned in the room connect them to the rear panel output terminals. For optimal reproduction we recommend the use of high quality speaker wire. Wire of min. 1.5 mm² is recommended for short runs (under 5 meters) and wire of 2 mm² or greater is recommended for longer runs. Be certain to observe polarity when connecting speakers by connecting the positive (+) and negative (-) terminals on the AVR11 to the like terminals on the speakers.

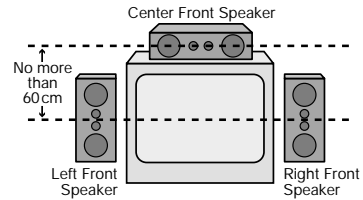

Front Channel Speaker Installation with Direct View TV Sets or Rear Screen Projectors

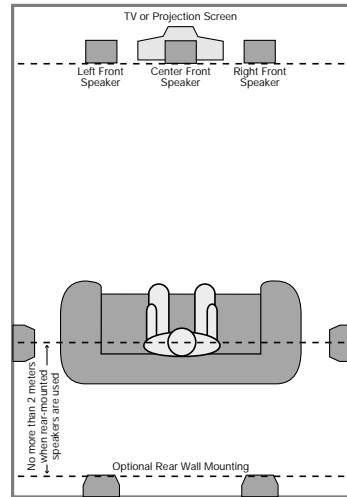

Speaker Placement Floor Plan

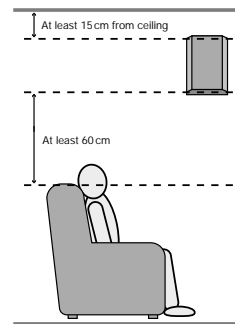

Surround Speaker Mounting Height

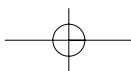

Installation & Configuration

8

If you wish to use an external amplifier for the front channel speakers follow the diagram on the inside front cover.

IMPORTANT NOTE: When connecting the AVR11 to a powered subwoofer be certain to connect BOTH the left and right subwoofer outputs on the AVR11 for proper low frequency imaging. If more than one subwoofer is used connect both outputs to each subwoofer speaker.

SURROUND MODE SELECTION

Surround sound processing enables four separate audio signals to be transmitted within the left and right channels. When a videocassette or video disc movie, television broadcast, CD or radio programme is advertised with the Dolby Surround™, DTS Stereo™ or UltraStereo™ logos or other indications that the programme has surround information you should select one of the AVR11's surround modes. This creates an enveloping sound field that places you in the center of the action. Clearer dialog, richer music and stunning ambiance effects turn your home into a movie theater or symphony hall with lifelike, multi-directional sound.

When listening to a programme that has surround information and you have rear channel speakers installed, press the **SURROUND MODE** Selection button on the front panel **4** until you see **PRO LOGIC** indicator illuminated in the front panel information window or directly press the button **PRO-LOGIC** on the remote.

If no rear channel speakers are in use, press the **SURROUND MODE** Selection button until you see the **DOLBY 3 STEREO** indicator illuminated or the direct key **3-STEREO** on the remote.

When listening to conventional stereo recordings you may wish to experiment with the use of the surround system, as an enjoyable soundfield may often be reproduced.

Press the **BYPASS** button on the front panel **3** or the button **SURROUND OFF** on the remote for conventional stereo reproduction using only the left and right speakers and the subwoofer.

CENTER CHANNEL MODE SELECTION

When Dolby ProLogic or Dolby 3 Stereo are in use the AVR11 permits you to tailor the center channel output to match the type of speakers used in your home theater. Press the **CENTER MODE** **11** button on the remote to select one of the following. The center channel mode is shown by indicators in the front panel display window.

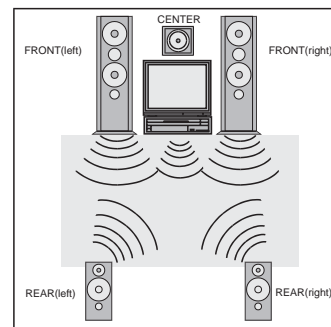

Normal Mode: Select this mode if your center channel is small and has limited bass response. Most specialized center channel speakers fall into this category.

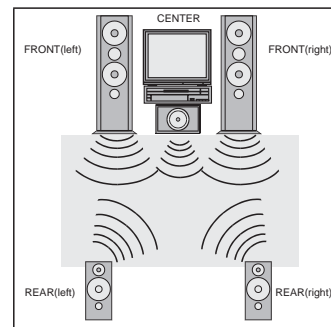

Wideband Mode: Select this mode if your center channel speaker is a traditional full range loudspeaker.

Installation & Configuration

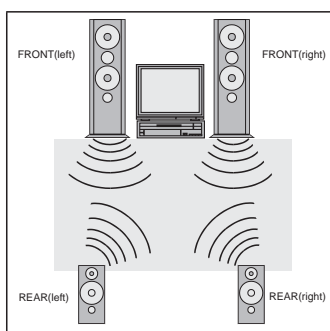

Phantom Mode: Select this mode if a center channel speaker is not used. The AVR11 will create a “phantom” center channel using the outputs of the left and right speakers. Note that the Phantom mode is not available when Dolby 3 Stereo is selected as a surround mode.

DELAY SETTINGS

Delay time adjustment enables you to adjust the timing between signals at the front and rear channels. While the factory setting is appropriate for most rooms, some installations create an uncommon distance between the front and rear speakers that may cause the front channel sounds to become disconnected from the surround channels.

To re-synchronize the front and rear channels press the **DELAY** button **8** on the remote until the delay between front and rear channels is more appropriate to your room.

OUTPUT LEVEL CALIBRATION

For proper operation in the surround modes it is important that the level from all channels be as close to one another as possible (with test signal). A small amount of time spent to properly calibrate the AVR11’s output levels will enable the unit to deliver all the performance it is capable of within the specific environment of your listening room.

IMPORTANT NOTE: Many people are confused about the operation of the surround channels. While some assume that sound should always be coming from each speaker, most of the time there will be little or no sound in the rear channels. This is because they are only used when a movie director or sound mixer specifically places sound there to create an effect or pull you into the action. When the output levels have been properly set it is normal for the rear speakers to only operate occasionally. Artificially increasing the volume to the rear speakers will destroy the illusion of an enveloping surround field that duplicates the way you hear sound in a movie theater or concert hall.

To calibrate your system, follow these steps:

1. Select the Dolby ProLogic mode using the **SURROUND MODE** **4** button on the front panel.

2. Place the front panel **BALANCE** **9** control at its midpoint position, so that the indicator is pointing straight up in the 12 o’clock position. If you normally leave the **BALANCE** control in another position to compensate for speaker placement relative to your preferred listening position, leave it in that spot.

3. Sit in the location that you will normally occupy when using your AVR11.

4. Press the **TEST** **12** button on the remote and note that a test noise signal will circulate between the channels.

- As the test noise circulates among the channels the word **TEST** and the channel name will appear in the front panel information display window. As the names change you should first listen to the location of the tone and verify that it matches the name displayed in the display. If the display indicates a different location than the speaker the test noise is coming from you should turn off the unit and verify that the connections to the speakers are made to the correct terminals on the rear panel.

5. As the test signal circulates among the channels, use the **CENTER LEVEL UP/DOWN** **10** and **REAR LEVEL UP/DOWN** **13** buttons on the remote to adjust the level so that the volume from all channels sounds equal.

6. Press the **TEST** button again to turn the test signal off. Your system is now properly calibrated and further volume adjustment should be made using the **MASTER VOLUME** buttons on the remote or the front panel volume control.

Operation

10

ENGLISH

1. Press the **POWER** button on the front panel **1** to turn the unit on. Note that the ring surrounding the power switch will turn green, the display will light and the volume indicator mark **20** will turn green.

If the unit thereby switches on to the Standby mode (that's the case if it was in Standby mode at switch off) it simply can be switched on by pressing any input selector on the front panel.

- If you wish to use the remote to turn the unit on and off, you must first engage the front panel power button. The unit may then be turned on and off by pressing the **STANDBY** **2** button on the remote. When using the remote the unit is placed in a "standby" mode rather than being totally shut off, and the ring surrounding the power button will glow amber.

- When you will be away from home for an extended period of time it is always best to turn the unit completely off using the front panel power button.

2. Select the desired program source using the input selector switches **3**. The name of the selected input source will appear in the information display window. When the tuner is in use, the selected station's frequency or RDS data will be displayed.

- When the selected input source is VCR1 or VCR2, the video signal for that input will be switched to the **VIDEO MONITOR OUT** jack and will be viewable on a TV Monitor connected to the AVR11. Be certain that your TV is set to the proper "VIDEO" input to view the signal.

3. Choose surround mode using the **SURROUND** mode select button **4**. Consult the Surround Mode selection section on page 8 for information on surround modes. To listen to traditional two channel (left/right) stereo press the **BYPASS** **3** button.

4. Adjust the **CENTER MODE** **11** and/or **DELAY TIME** **6** if a change is required from the setting established during installation.

5. Adjust the volume to a comfortable level using the front panel volume control **21** or the up/down volume controls on the remote **14**.

6. To temporarily silence the output to the speakers press the **MUTE** button on the remote **17**. Press the button again to resume normal listening.

7. For private listening, insert the 6,3 mm stereo plug from a pair of headphones into the **HEADPHONES** jack **2**. Note that when the headphones are plugged in the sound from the speakers is automatically cut off.

TUNER OPERATION

The AVR11's built in tuner is capable of tuning AM, FM or FM Stereo broadcast stations, and features the added benefits of RDS operation. Stations may be tuned manually, automatically or via presets.

Manual Tuning

1. Press the **FM/AM** button **6** to select the tuner as an input and the desired frequency band.

2. Press the **SEEK/STEREO** **13** button so that the **AUTO** indicator in the display is not on.

3. Press the **TUNING/PTY** **17** button until the desired station is tuned. Holding the button down will cause a rapid advance through the frequency band, while tapping it lightly will advance through bands one increment at a time.

4. Note that the **TUNE D** indicator will illuminate when a station is received with sufficient strength for quality reception.

5. Press the **SEEK/STEREO** **13** button to switch between mono and stereo reception. In cases where a station's signal is weak, press the button until the **AUTO** indicator in the information display goes out. This will switch the tuner to mono, but it may enable clearer reception of the signal.

Operation

11

ENGLISH

Auto Tuning

1. Press the **FM/AM** **6** button to select the tuner as an input and the desired frequency band.

2. Press the **SEEK/STEREO** **13** button, so that the AUTO indicator in the display goes on.

3. Press the **TUNING/PTY** **▲▼** **17** button once and tuning will start in the direction indicated. The tuner will stop at the next station with sufficient signal strength.

Preset Memory

Up to 30 stations may be stored in the receiver's memory for easy recall using the front panel controls or the remote.

To enter a station to the memory, first tune to the station using the steps outlined above in the Manual Tuning section. Then:

1. Press the **MEMORY** **12** button on the front panel. Note that the **MEM** indicator in the information display window will illuminate and flash.

2. Within five seconds, press the station preset **11** button corresponding to the memory location where you wish to store this station's frequency.

- To enter a station to memory location "30" press only the "0" button.

3. Repeat the process after tuning to any additional stations to be preset.

Recalling Preset Stations

To select a station that has previously been entered into the preset memory simply press the station preset **11** buttons on the front panel or the numeric **6** buttons on the remote corresponding to the desired station's location. To select the station in location "30", press the **0** button only.

- When you select a station using this method the unit will automatically switch to the tuner as its input.

Preset Station Scan

To automatically scan through the stations that have been entered to the preset memory, press the **P•SCAN** **4** button on the remote. The tuner will automatically begin to search through the list of stations, stopping for four seconds at each one. Press the **P•SCAN** button again to stop the scan at your desired station.

RDS OPERATION

Your AVR11 is equipped with RDS (Radio Data System), which brings a wide range of information to FM radio. Now in use in many countries, RDS is a system for transmitting station call signs or network information, a description of station programming, text messages about the station or specifics of a musical selection and the correct time.

As more FM stations become equipped with RDS capabilities, the AVR11 will serve as an easy to use center for both information and entertainment. This section will help you to take maximum advantage of the RDS system

RDS Tuning

To tune stations that are broadcasting RDS data press the **RDS** **16** button on the front panel and note that the **RDS** indicator illuminates in the front panel display window.

Next, press the **TUNING/PTY** **17** button in either the **▲** or **▼** direction. The unit will automatically seek the first station with RDS data and stop there. The station name or programme service information will be displayed in the information display window in place of the normal frequency display.

Press the **TUNING/PTY** **17** button again to tune to the next RDS station. Remember that the **RDS** **16** button must be pressed again to tune all stations, not just those sending RDS data.

Operation

12

ENGLISH



Programme Search (PTY)

A major benefit of RDS is its ability to encode broadcasts with Programme Type (PTY) codes that indicate the type of material being broadcast. The following list shows the abbreviation used to indicate each PTY in the front panel information display along with an explanation of the PTY:

- NEWS
- AFFAIRS: Political and current events
- INFO: General information, financial and trading news, medical conference and weather information
- SPORT: Sporting Events
- EDUCATE: Scholastic and industrial education programmes
- DRAMA: Broadcast plays and literature performances
- CULTURE: Cultural, religion and community programmes
- SCIENCE: Scientific and technical programmes
- VARIED: Entertainment
- POP M: Popular music
- ROCK M: Rock music
- M O R: Middle of the Road Music
- LIGHT M: Light Classical Music
- CLASSICS: Serious Classical Music
- O T H E R M: Other types of musical programmes. i.e., Jazz, Reggae, Rap, etc.
- ALARM: Emergency Warnings
- NONE: (PTY Undefined)

The AVR11 allows you to scan for a specific PTY by using the following steps:

Press the **RDS**  button until the RDS indicator illuminates.

Press the **PTY**  button on the front panel. The information display will read **PTY SEL**. While this display is still visible press the **TUNING/PTY**  button to scroll up or down through the list of possible programme types until the desired PTY is shown in the display.

While your desired PTY is still visible in the display press the **PTY**  button again. The tuner will scan through the stations in the preset memory for those that match the desired PTY.

When the scan is finished a list of the preset locations for the RDS stations broadcasting the selected programme will appear briefly in the display window (i.e., 04/13/25). The unit will automatically tune to the station in the group with the strongest signal.

NOTE: Make note of the preset locations shown, as you may wish to manually select an alternate station. Although all stations indicated will be broadcasting the same programme type, they may not be broadcasting the identical programme.

Radio Text (RT) Display

Some stations include additional information in their RDS transmissions such as information about the station, the current programme or the current musical selection's title or artist. Since this information may be too long to fit in the standard RDS display, the **RADIO TEXT (RT)** function will automatically scroll the text across the information display.

To view the RT display you must be listening to a station that is transmitting RDS data. Press the **RT**  button on the front panel to access the display.

The word **TEXT** will flash in the display window as the receiver checks for an RT message. If a message is detected it will automatically scroll across the display. To return to the standard RDS display, press the **RT**  button again, or switch to a different input.

NOTE: The RT function requires a strong signal for proper operation. If you receive a partial message or see letters in the text replaced with asterisks ("*") try slowly adjusting the FM antenna to improve the signal strength or tune to another, stronger, RDS station.

Operation

13

ENGLISH

RDS Display Options

The RDS system enables a variety of information to be transmitted as inaudible codes in the broadcast signal. Pressing the **DISPLAY** **[9]** button on the front panel enables you to view data being transmitted by an RDS station.

In normal operation the display will indicate the station name, broadcast network or call letters (PS). Press the **DISPLAY** button to read each of the following in sequence:

The current Programme Type (PTY) as shown on the above list.

The current time (CT), as transmitted by the station.

The frequency of the station.

The next button press will return you to the Station Name (PS) display.

NOTE: If the data required for the selected display mode is not currently being transmitted, a message to that effect will be shown in the main display.

RECORDING WITH AN AUDIO TAPE/CASSETTE DECK

1. Select the program source to be recorded with the input selector switches **[6]** **[9]** on the front panel or the remote.
2. Start the recording. The output to the speakers will be identical to that going to the recorder.
3. If you are using a three-head cassette or tape deck, the recorded sound may be monitored through the speakers by pressing the **TAPE MON** **[5]** button on the front panel. The **TAPE** indicator will illuminate in the information window to remind you that you are listening to the tape playback, not the source.

NOTE: When a recording is being made the volume, balance, bass and treble controls may be adjusted without having any effect on the recording or dubbing.

Dubbing from VCR2 to VCR1

1. Press the **VCR2** **[6]** button to select the input source.
2. Place the VCR connected to the **VCR1** input in the "record" mode.
3. Start the VCR connected to the front panel **VCR2** inputs. The audio and video signals will be dubbed onto **VCR1**.

Recording with separate video and audio sources

When dubbing from VCR2 to VCR1 you may replace the audio signal from VCR2's programme with another source.

1. Press the **VCR2** **[6]** button to select the input source.
2. Press the input selector **[6]** button corresponding to the audio source you wish to record (i.e., FM/AM, CD, TV/AUX, TAPE).
3. Place the VCR connected to the **VCR1** input in the "record" mode.
4. Start the playback on **VCR2** and the selected audio source.

This allows you to watch the picture from the Video component at VCR2 and listen to the sound from the selected Audio Component while recording.

NOTE: Be sure to observe the order of steps 1 and 2.

Troubleshooting

This unit is designed for trouble-free operation. Most problems users encounter are due to operating errors. So, if you have a problem, first check this list for a possible solution. If the problem persists, consult your authorized Harman Kardon Service Center.

If the problem is...	Make sure that the...
No lights illuminate when POWER button is pressed	Unit is plugged into a live outlet
No sound is heard	Correct input function selector button has been pressed Volume is turned up Speakers are connected properly
Dolby Surround does not work on center and rear channels	Correct surround mode is selected Rear and Center levels are turned up Dolby Surround material is used as source
Selecting video component produces sound but no picture	Video cables are connected properly
The TV picture does not match the sound	Video sources are properly connected to receiver Video/Antenna Switch on TV is set to Video
No output from one or more channels	Cables are not defective: Check/replace speaker cables The signal source is operating and providing proper signal output to the AVR11
No center channel output	Dolby surround or 3 stereo is turned on Phantom mode is not active
Tuner sound has a large amount of interference, or The "Stereo" display is not illuminated, or Tuner sound distorts and/or is noisy	The antenna is properly connected The antenna is properly located The antenna is set in the proper direction The antenna is adequate to receive the desired station
Tuner is intermittent or continuously buzzing or hissing	The unit is away from fluorescent lights, TVs, motors and other electrical appliances
Stations cannot be preset	After pressing the Memory button, the Preset button is pressed while the memory indicator blinks

Specifications

Stereo Mode

Continuous Average Power (FTC)
 40 Watts from 20Hz-20kHz: @<0.09% THD, both channels driven into 8 Ohms

Five Channel Surround Mode

Continuous average power per channel (FTC)
 Front L&R channels
 2x40Watts from 20Hz-20kHz: @<0.2% THD, both channels driven into 8 Ohms
 Center channel
 45 Watts at 1kHz: @<0.9% THD, driven into 8 Ohms
 Rear channels
 2 x 22,5 Watts at 1kHz: @<1.0% THD, both channels driven into 4 Ohms

Amplifier Section

High-Instantaneous Current Capability (HCC): ±20 Amps
 Negative Feedback: 26dB
 Frequency Response @1W (+0/-3dB): 5Hz-120kHz
 Rise Time: 1.8µSec
 Transient Intermodulation Distortion (TIM): Unmeasurable

Preamplifier Section

Signal-to-Noise Ratio (ref. 35 Watts, A-Wtd)
 CD: 95dB
 Video: 85dB
 Input Sensitivity/Impedance
 Video, CD, Tape: 150mV/22kOhms
 Tone Control Range
 Bass @ 50Hz: ±10dB
 Treble @ 10kHz: ±10dB

Tuner Section: FM

Usable Sensitivity, Mono (dbf): < 14.2
 46dB Quieting Sensitivity, Stereo (dbf): < 49.3
 Signal-to-Noise Ratio (IHF) @ 65dBf, mono/stereo: > 65dB/62dB (DIN)
 Capture Ratio: < 2.0dB
 Selectivity, Adjacent/Alternate Channel (150/300 kHz): > 5dB/65dB
 IF Rejection: 90dB
 AM Rejection @ 45dBf: 50dB
 Stereo Separation @ 1kHz, 65dBf: > 35dB
 THD @ 1kHz, 65dBf, mono/stereo (%): < 0.3/0.5

Tuner Section: AM

Sensitivity, External Antenna: < 500µV/m
 Alternate Channel Selectivity: >25dB
 Image Rejection: >35dB
 IF Rejection: >50dB

General

Dimensions (WxHxD): mm: 440 x 142 x 360
 Weight (kgs/lbs): 8.2 kg, 18 lbs

Depth measurement includes knobs, buttons and jacks.

Height measurement includes feet.

All features and specifications are subject to change without notice.

Manufactured under license from Dolby Laboratories Licensing Corporation. Additionally licensed under one or more of the following patents: U.S. number 3,959,590; Canadian numbers 1,004,603 and 1,037,877. "Dolby", "Pro Logic" and the double-D symbol are trademarks of Dolby Laboratories Licensing Corporation.

